

# THEORETICAL EYE MODELS COMPARISON BASED ON MTF EVOLUTION

A. STURZU<sup>1</sup>

D. LUCA-MOTOC<sup>1</sup>

**Abstract:** *The paper focuses on a computer aided approach of few theoretical eye models, more or less widespread within literature, with the aim of quantifying the modulation transfer function on image formation. One of the theoretical models takes into account the age related influence on the eye lens structural parameters as an independent issue and all of them were implemented using OSLO 6.4.5 optical software. The MTF evolution in case of the herein models were subjected to comparison to aid image quality evaluation on imaginary retinal surface.*

**Key words:** *eye, models, age related, image quality, MTF.*

## 1. Introduction

Literature provides numerous studies with respect to the age related changes of the eye structural parameters, being acknowledged the fact that the most influenced is the eye lens [1-3].

Most early eye models such as Emsley's reduced eye, Gullstrand simplified or Gullstrand-le Grand eye, Swiegerling eye can be described as ideal theoretical models due to their assumptions valid in the paraxial domain [5], [8-9], [11-12].

The Arizona eye model that was used also in the present study is one of the recently developed theoretical eye model and far the most comprehensive comparatively with the previously ones.

It takes into account the eye related structural parameters modification (e.g. refractive index, radius surfaces and thickness) [4], [13-14].

Modulation transfer function (MTF) is a

quantitative measure of image quality being superior to any resolution criteria.

MTF describes the ability of a lens or system to transfer object contrast to the image and the retrieved data can be used to determine the feasibility of overall system expectations.

MTF should be used to verify that a system is performing as it is expected and intended to be performing [6-7], [10].

The herein paper attempts to compare the main and feasible theoretical eye models from MTF evolution point of view with the purpose of sizing the influence of the optical layouts on the overall system performance.

The OSLO 6.4.5 software was chosen to design the eye optical layout using as data input the previous theoretical eye models.

Age related variations for the anterior and posterior lens curvatures were introduced with the aim of sizing the influences on the image formation and

---

<sup>1</sup> Dept. of Precision Mechanics and Mechatronics, *Transilvania* University of Braşov.

other design parameters (e.g. PSF - Point Spread Function, spot diagram etc.).

## 2. Theoretical Backgrounds

### 2.1. MTF issues

The sharpness and contrast of an imaging system or of a component of the system may be characterized by the Modulation Transfer Function (MTF), also known as spatial frequency response. The MTF curve has different meanings according to the corresponding frequency. Its height at frequencies of 1.5 cycles/degree represents the contrast-behavior of the optical system. It is known from literature that a good optical system should perform over 95% at this frequency for both sagittal and tangential directions, and values worse than 90% represents a bad performance.

Frequencies in the gap of 3 to 12 or higher cycles/degree represent the sharpness-

ability of an optical system. MTF readings taken at 12 cycles/degree indicate how good an optical system can transmit very fine structures.

For an optimal quality based on the human eye, the lens should perform over 50% at 6 cycles/degree. Perceived image sharpness is more closely related to the spatial frequency where MTF is 50% (0.5), where contrast has dropped by half. Typical 50% MTF frequencies are often as low as 9 cycles/degree for the entire optical system.

### 2.2. Theoretical eye models

In Table 1 to Table 4 are being listed the input data for the computer simulation. Data represents values related to the refraction indices, radius curvature, thickness and distances on the central optical path as well as age related dependences for the Arizona eye model (see Table 5).

*Emsley model (1946)*

Table 1

Surface	Radius [mm]	Thickness [mm]	Refractive index	Medium
1	5.5	22.22	1.3333	Cornea
2	$\infty$			Retina

*Liou-Brennan model (1997)*

Table 2

Surface	Radius [mm]	Asphericity	Thickness [mm]	Refractive index	Medium
1	7.77	-0.18	0.50	1.376	Cornea
2	6.40	-0.60	3.16	1.336	Aqueous
3	12.40	-0.94	1.59	Grad A	Lens
4	$\infty$	-	2.43	Grad P	Vitreous
5	-8.10	0.96	16.27	1.336	Retina

*Koojiman model (1983)*

Table 3

Surface	Radius [mm]	Asphericity	Thickness [mm]	Refractive index	Medium
1	7.8	0.75	0.55	1.3771	Cornea
2	6.5	0.75	3.05	1.3374	Aqueous
3	10.2	-2.06	4.0	1.420	Lens
4	-6.0	0.01	16.60	1.336	Vitreous
5	-14.1				Retina

*Arizona model*

Table 4

Surface	Radius [mm]	Asphericity	Refractive index	Abbe coefficient	Thickness [mm]	Medium
1	7.8	-0.25	1.377	57.1	0.55	Cornea
2	6.5	-0.25	1.337	61.3	$t_1$	Aqueous
3	$r_1$	$p_1$	$n_1$	51.9	$t_2$	Lens
4	$r_2$	$p_2$	1.336	61.1	16.713	Vitreous
5	-13.4					Retina

*Age related structural parameters in Arizona model*

Table 5

Radius [mm]	Thickness [mm]	Conic parameter	Refractive index
$R_1 = 12.0 - 0.4 \text{ age}$	$t_1 = 2.97 - 0.04 \text{ age}$	$K_1 = -7.518749 + 1.285720 \text{ age}$	$n_1 = 1.42 + 0.00256 \text{ age} - 0.00022 \text{ age}^2$
$R_2 = -5.224557 + 0.2 \text{ age}$	$t_2 = 3.767 + 0.04 \text{ age}$	$K_2 = -1.353971 - 0.431762 \text{ age}$	

The theoretical eye models were developed based on experimental measures on representative statistical sample of investigated patients. The most used optometric devices were the Optical Coherence Tomography (OCT) and ultrasonic or auto-refractometer allowing other ocular deficiencies to be highlighted (see Figures 1 and 2).

The eye lens aspheric surfaces are being described function of a conic constant, the sag of surface being given by the following expression:

$$z = \frac{\frac{r^2}{R}}{1 + \sqrt{1 - (1 + K)\left(\frac{r}{R}\right)^2}}, \quad (1)$$

$R$  being the surface radius,  $r$  takes into account the incident ray position and  $K$  takes values between  $-1$  and  $0$ , less and higher than these ( $K < -1$  hyperboloid,  $K = -1$  paraboloid,  $K = 0$  sphere,  $K > 0$  ellipsoid).

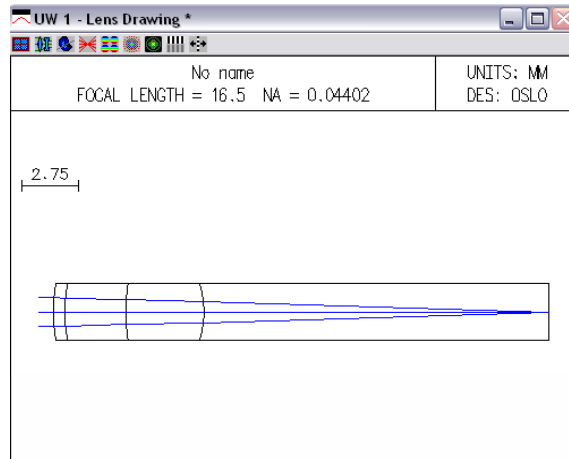

Fig. 1. *Arizona model (2D plan view)*

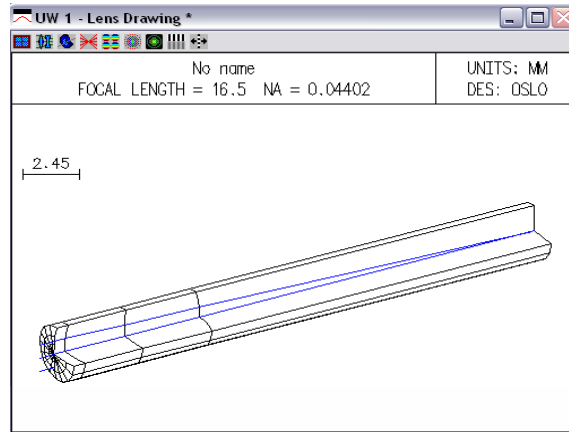

Fig. 2. Arizona model (3D solid facets)

### 3. Results and Discussions

All the tangential and sagittal MTF curves obtained for all 4 models are presented in Figures 3 to 6. The tangential

and the sagittal modulation transfer functions were plotted together to illustrate the influence of optical layouts (e.g. surface related parameters, refraction indices, and thickness).

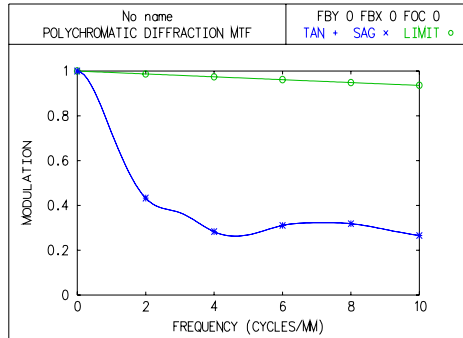

Fig. 3. Emsley model

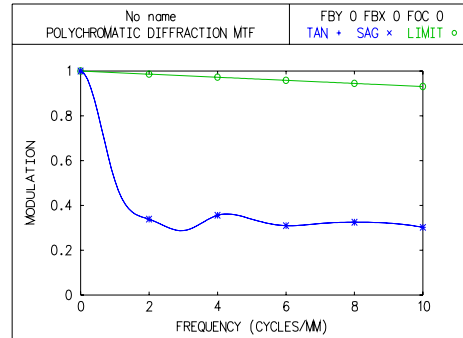

Fig. 4. Koojiman model

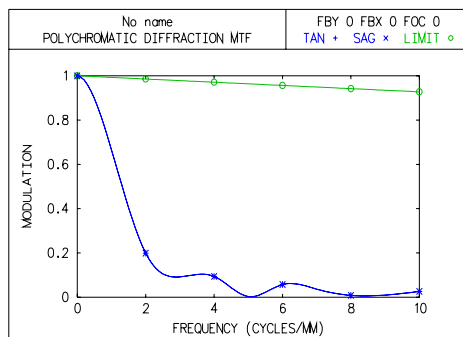

Fig. 5. Liou-Brennan model

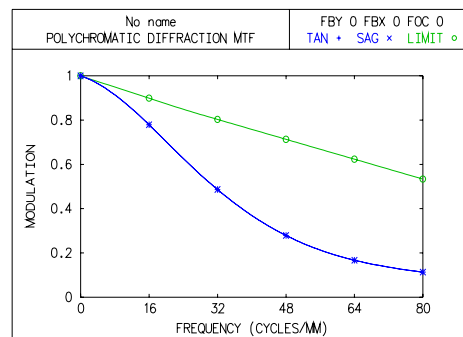

Fig. 6. Arizona model

As it can be seen the Emsley and Koojiman theoretical models perform better from sharpness-ability point of view, whereas the Arizona theoretical model, one of the most comprehensive, performs better among all of them, especially in transmitting information on image details.

The Liou-Brennan model seems to reveal a better contrast-behaviour in vicinity of 1.5 cycles/degree but in the sagittal plane it performs less compared with the other models.

The reason for this difference between the tangential and the sagittal MTF on the Liou-Brennan model is that, although the object is on-axis, it is not rotationally symmetric about the axis of the eye which means that the MTF will not be rotationally symmetrical.

#### 4. Conclusions

A modulation transfer function based comparison in case of four most comprehensive theoretical models known from literature reveals that all of them provide images with higher quality than was expected.

The Liou-Brennan's model does not have the best MTF but is the one that most closely approximates to the *in vivo* human eye.

Another type of comparison, which was not presented here but carried out by the author and would certainly add value to the other types of optical quality parameters used, is the spot diagrams, Strehl ratio and the 3<sup>rd</sup> and the 5<sup>th</sup> order of Seidel aberrations for each eye model.

A comparison of retrieved values would clearly and quantitatively indicate the benefits of each model in terms of individual aberrations.

Supplementary, further studies may allow development of other theoretical models closely related to the performance of the human eye.

#### References

1. Atchison, D., Jones, C.E., Schmid, K.L., et al.: *Eye Shape in Emmetropia and Myopia*. In: *Investigative Ophthalmology and Visual Science* **45** (2005) No. 10, p. 3380-3386.
2. Atchison, D., Schmid, K.L., Pritchard, N.: *Neural and Optical Limits to Visual Performance in Myopia*. In: *Vision Research* **46** (2006) Issue 21, p. 3707-3722.
3. Atchison, D.: *Optical Models for Human Myopic Eyes*. In: *Vision Research* **46** (2006) Issue 14, p. 2236-2250.
4. Brown, N.P.: *The Change in Lens Curvature with Age*. In: *Experimental Eye Research* **19** (1974) Issue 2, p. 175-183.
5. Doshi, J., Sarver, E.J., et al.: *Schematic Eye Models for Simulation of Patient Visual Performance*. In: *Journal of Refractive Surgery* **17** (2001), p. 414-419.
6. Einigshammer, J., Oltrup, T., et al.: *The Individual Virtual Eye: A Computer Model for Advanced Intraocular Lens Calculation*. In: *Journal of Optometry* **2** (2009), p. 70-82.
7. Grievenkamp, J.E., Schwielerling, J., Miller, J.M., et al.: *Visual Acuity Modelling Using Optical Ray Tracing of Schematic Eyes*. In: *American Journal of Ophthalmology* **120** (1995), p. 227-240.
8. Gullstrand, A.: *Appendices to Part I*. In: *Physiologic optics*, von Helmholtz, H. (Ed.), 3<sup>rd</sup> Edition, Vol. 1, Hamburg, Germany - Voss, 1909, p. 350-358.
9. Guo, H., Wang, Z., et al.: *Individual Eye Model Based on Wavefront Abberation*. In: *International Journal for Light and Electron Optics* **116** (2005), p. 80-85.
10. Rynders, M., Lidkea, B., Chisholm, W., Thibos, L.N.: *Statistical Distribution of Foveal Transverse Chromatic*

- Aberration, Pupil Centration and Angle Psi in a Population of Young Adult Eye.* In: Journal of Optometry Society American A **12** (1995), p. 2348-2357.
11. Smith, G., Atchison, D., Iskander, D.R., et al.: *Mathematical Models for Describing the Shape of the in Vitro Unstretched Human Crystalline Lens.* In: Vision Research **49** (2009) Issue 20, p. 2442-2452.
12. Sturzu, A., Cernea, C.: *Computer Aided Lens Prescription based on Wave Aberration Identification.* In: Proceedings to the Annual Session of Scientific Papers of IMT Oradea, 2010, p. 34-38.
13. Wang, Y., Wang, Z., et al.: *Intraocular Lens Design for Treating High Myopia based on Individual Eye Model.* In: International Journal for Light and Electron Optics **118** (2007) No. 2, p. 88-93.
14. <http://www.optics.arizona.edu/opti510l/references/eye%20models.pdf>. Accessed: 06.01.2010.